

Ultra-Low $V_{CE(sat)}$ IGBT with Diode

IXGH 31N60D1 IXGT 31N60D1

$V_{CES} = 600 \text{ V}$
 $I_{C25} = 60 \text{ A}$
 $V_{CE(sat)} = 1.7 \text{ V}$

Preliminary data

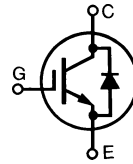

| Symbol | Test Conditions | Maximum Ratings | |
|---|---|----------------------------------|------------------|
| V_{CES} | $T_J = 25^\circ\text{C}$ to 150°C | 600 | V |
| V_{CGR} | $T_J = 25^\circ\text{C}$ to 150°C ; $R_{GE} = 1 \text{ M}\Omega$ | 600 | V |
| V_{GES} | Continuous | ± 20 | V |
| V_{GEM} | Transient | ± 30 | V |
| I_{C25} | $T_C = 25^\circ\text{C}$ | 60 | A |
| I_{C90} | $T_C = 90^\circ\text{C}$ | 31 | A |
| I_{CM} | $T_C = 25^\circ\text{C}$, 1 ms | 80 | A |
| SSOA (RBSOA) | $V_{GE} = 15 \text{ V}$, $T_{VJ} = 125^\circ\text{C}$, $R_G = 10 \Omega$ Clamped inductive load, $L = 100 \mu\text{H}$ | $I_{CM} = 62$ @ $0.8 V_{CES}$ | A |
| P_C | $T_C = 25^\circ\text{C}$ | 150 | W |
| T_J | | -55 ... +150 | $^\circ\text{C}$ |
| T_{JM} | | 150 | $^\circ\text{C}$ |
| T_{stg} | | -55 ... +150 | $^\circ\text{C}$ |
| M_d | Mounting torque (M3) TO-247 | 1.13/10 | Nm/lb.in. |
| Maximum lead temperature for soldering 1.6 mm (0.062 in.) from case for 10 s | | 300 | $^\circ\text{C}$ |
| Weight | TO-247 | 6 | g |
| | TO-268 | 4 | g |

TO-268
(IXGT)

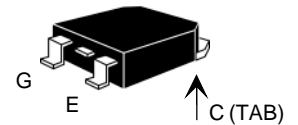

TO-247 AD
(IXGH)

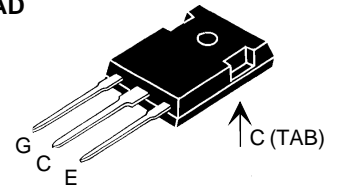

G = Gate, C = Collector,
E = Emitter, TAB = Collector

Features

- IGBT and anti-parallel FRED in one package
- Low $V_{CE(sat)}$
 - for minimum on-state conduction losses
- MOS Gate turn-on
 - drive simplicity
- Fast Recovery Epitaxial Diode (FRED)
 - soft recovery with low I_{RM}

Applications

- AC motor speed control
- DC servo and robot drives
- DC choppers
- Uninterruptible power supplies (UPS)
- Switch-mode and resonant-mode power supplies

Advantages

- Space savings (two devices in one package)
- Easy to mount with 1 screw (isolated mounting screw hole)
- Reduces assembly time and cost
- High power density

| Symbol | Test Conditions | Characteristic Values ($T_J = 25^\circ\text{C}$, unless otherwise specified) | | |
|---------------|--|---|------|----------------------|
| | | min. | typ. | max. |
| BV_{CES} | $I_C = 250 \mu\text{A}$, $V_{GE} = 0 \text{ V}$ | 600 | | V |
| $V_{GE(th)}$ | $I_C = 250 \mu\text{A}$, $V_{CE} = V_{GE}$ | 2.5 | | V |
| I_{CES} | $V_{CE} = 0.8 \cdot V_{CES}$ $V_{GE} = 0 \text{ V}$ | $T_J = 25^\circ\text{C}$ | | 200 μA |
| | | $T_J = 125^\circ\text{C}$ | | 3 mA |
| I_{GES} | $V_{CE} = 0 \text{ V}$, $V_{GE} = \pm 20 \text{ V}$ | | | $\pm 100 \text{ nA}$ |
| $V_{CE(sat)}$ | $I_C = I_{C90}$, $V_{GE} = 15 \text{ V}$ | | | 1.7 V |

| Symbol | Test Conditions | Characteristic Values ($T_J = 25^\circ\text{C}$, unless otherwise specified) | | |
|--------------|--|---|------|----------|
| | | min. | typ. | max. |
| g_{fs} | $I_C = I_{C90}$; $V_{CE} = 10\text{ V}$, Pulse test, $t \leq 300\ \mu\text{s}$, duty cycle $\leq 2\%$ | 10 | 16 | S |
| C_{ies} | $V_{CE} = 25\text{ V}$, $V_{GE} = 0\text{ V}$, $f = 1\text{ MHz}$ | | 1500 | pF |
| C_{oes} | | | 130 | pF |
| C_{res} | | | 40 | pF |
| Q_g | $I_C = I_{C90}$, $V_{GE} = 15\text{ V}$, $V_{CE} = 0.5 V_{CES}$ | | 80 | 100 nC |
| Q_{ge} | | | 15 | 30 nC |
| Q_{gc} | | | 30 | 40 nC |
| $t_{d(on)}$ | Inductive load, $T_J = 25^\circ\text{C}$ $I_C = I_{C90}$, $V_{GE} = 15\text{ V}$, $L = 100\ \mu\text{H}$, $V_{CE} = 0.8 V_{CES}$, $R_G = R_{off} = 10\ \Omega$ Remarks: Switching times may increase for $V_{CE}(\text{Clamp}) > 0.8 \cdot V_{CES}$, higher T_J or increased R_G | | 15 | ns |
| t_{ri} | | | 25 | ns |
| $t_{d(off)}$ | | | 400 | 800 ns |
| t_{fi} | | | 400 | 800 ns |
| E_{off} | | | 6 | mJ |
| $t_{d(on)}$ | Inductive load, $T_J = 125^\circ\text{C}$ $I_C = I_{C90}$, $V_{GE} = 15\text{ V}$, $L = 100\ \mu\text{H}$ $V_{CE} = 0.8 V_{CES}$, $R_G = R_{off} = 10\ \Omega$ Remarks: Switching times may increase for $V_{CE}(\text{Clamp}) > 0.8 \cdot V_{CES}$, higher T_J or increased R_G | | 15 | ns |
| t_{ri} | | | 25 | ns |
| E_{on} | | | 1 | mJ |
| $t_{d(off)}$ | | | 800 | ns |
| t_{fi} | | | 800 | ns |
| E_{off} | | | 12 | mJ |
| R_{thJC} | | | | 0.83 K/W |
| R_{thCK} | | | | 0.25 K/W |

| Symbol | Test Conditions | Characteristic Values ($T_J = 25^\circ\text{C}$, unless otherwise specified) | | |
|------------|---|---|------|--------|
| | | min. | typ. | max. |
| V_F | $I_F = I_{C90}$, $V_{GE} = 0\text{ V}$, Pulse test, $t \leq 300\ \mu\text{s}$, duty cycle $d \leq 2\%$ | $T_J = 150^\circ\text{C}$ | | 1.6 V |
| | | $T_J = 25^\circ\text{C}$ | | 2.5 V |
| I_{RM} | $I_F = I_{C90}$, $V_{GE} = 0\text{ V}$, $-di_F/dt = 100\text{ A}/\mu\text{s}$ $V_R = 100\text{ V}$ $I_F = 1\text{ A}$; $-di/dt = 100\text{ A}/\mu\text{s}$; $V_R = 30\text{ V}$ | $T_J = 100^\circ\text{C}$ | | 6 A |
| t_{rr} | | $T_J = 25^\circ\text{C}$ | | 100 ns |
| | | | | 25 ns |
| R_{thJC} | | | | 1 K/W |

Min. Recommended Footprint

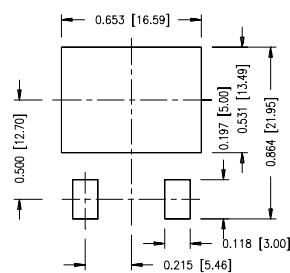

TO-247 AD (IXGH) Outline

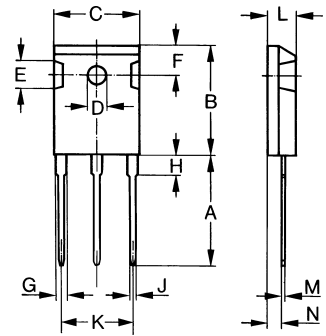

| Dim. | Millimeter | | Inches | |
|------|------------|-------|--------|-------|
| | Min. | Max. | Min. | Max. |
| A | 19.81 | 20.32 | 0.780 | 0.800 |
| B | 20.80 | 21.46 | 0.819 | 0.845 |
| C | 15.75 | 16.26 | 0.610 | 0.640 |
| D | 3.55 | 3.65 | 0.140 | 0.144 |
| E | 4.32 | 5.49 | 0.170 | 0.216 |
| F | 5.4 | 6.2 | 0.212 | 0.244 |
| G | 1.65 | 2.13 | 0.065 | 0.084 |
| H | - | 4.5 | - | 0.177 |
| J | 1.0 | 1.4 | 0.040 | 0.055 |
| K | 10.8 | 11.0 | 0.426 | 0.433 |
| L | 4.7 | 5.3 | 0.185 | 0.209 |
| M | 0.4 | 0.8 | 0.016 | 0.031 |
| N | 1.5 | 2.49 | 0.087 | 0.102 |

TO-268AA (D³ PAK)

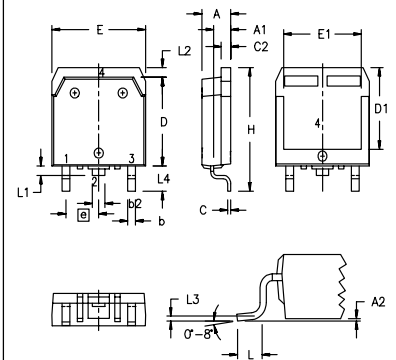

| Dim. | Millimeter | | Inches | |
|----------------|------------|-------|----------|------|
| | Min. | Max. | Min. | Max. |
| A | 4.9 | 5.1 | .193 | .201 |
| A ₁ | 2.7 | 2.9 | .106 | .114 |
| A ₂ | .02 | .25 | .001 | .010 |
| b | 1.15 | 1.45 | .045 | .057 |
| b ₂ | 1.9 | 2.1 | .75 | .83 |
| C | .4 | .65 | .016 | .026 |
| D | 13.80 | 14.00 | .543 | .551 |
| E | 15.85 | 16.05 | .624 | .632 |
| E ₁ | 13.3 | 13.6 | .524 | .535 |
| e | 5.45 BSC | | .215 BSC | |
| H | 18.70 | 19.10 | .736 | .752 |
| L | 2.40 | 2.70 | .094 | .106 |
| L ₁ | 1.20 | 1.40 | .047 | .055 |
| L ₂ | 1.00 | 1.15 | .039 | .045 |
| L ₃ | 0.25 BSC | | .010 BSC | |
| L ₄ | 3.80 | 4.10 | .150 | .161 |