

# AC Controller Modules

**$I_{RMS} = 112 \text{ A}$**   
 **$V_{RRM} = 800-1400 \text{ V}$**

## Preliminary Data

$V_{RSM}$ $V_{DSM}$ V	$V_{RRM}$ $V_{DRM}$ V	Type
800	800	MMO 110-08io7
1200	1200	MMO 110-12io7
1400	1400	MMO 110-14io7

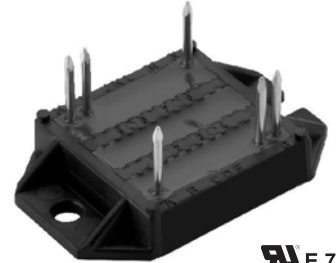
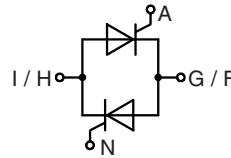

E 72873

Symbol	Conditions	Maximum Ratings	Features
$I_{RMS}$	$T_C = 85^\circ\text{C}$ , 50 - 400 Hz, module	112 A	<ul style="list-style-type: none"> <li>Thyristor controller for AC (circuit W1C acc. to IEC) for mains frequency</li> <li>Isolation voltage 3000 V~</li> <li>Planar glass passivated chips</li> <li>Low forward voltage drop</li> <li>Lead suitable for PC board solering</li> </ul>
$I_{TRMS}$		81 A	
$I_{TAVM}$	$T_C = 85^\circ\text{C}$ ; (180° sine)	51 A	
$I_{TSM}$	$T_{VJ} = 45^\circ\text{C}$ $V_R = 0$	t = 10 ms (50 Hz), sine: 1000 A t = 8.3 ms (60 Hz), sine: 1070 A	
	$T_{VJ} = 125^\circ\text{C}$ $V_R = 0$	t = 10 ms (50 Hz), sine: 870 A t = 8.3 ms (60 Hz), sine: 930 A	
$I^2t$	$T_{VJ} = 45^\circ\text{C}$ $V_R = 0$	t = 10 ms (50 Hz), sine: 5000 A <sup>2</sup> s t = 8.3 ms (60 Hz), sine: 4810 A <sup>2</sup> s	
	$T_{VJ} = 125^\circ\text{C}$ $V_R = 0$	t = 10 ms (50 Hz), sine: 3780 A <sup>2</sup> s t = 8.3 ms (60 Hz), sine: 3630 A <sup>2</sup> s	
$(di/dt)_{cr}$	$T_{VJ} = 125^\circ\text{C}$ f = 50 Hz, $t_p = 200 \mu\text{s}$ $V_D = \frac{2}{3} V_{DRM}$ $I_G = 0.45 \text{ A}$ $di_G/dt = 0.45 \text{ A}/\mu\text{s}$	repetitive, $I_T = 50 \text{ A}$ : 100 A/ $\mu\text{s}$ non repetitive, $I_T = I_{TAVM}$ : 500 A/ $\mu\text{s}$	
	$T_{VJ} = 125^\circ\text{C}$ ; $V_{DR} = \frac{2}{3} V_{DRM}$ $R_{GK} = \infty$ ; method 1 (linear voltage rise)	1000 V/ $\mu\text{s}$	
$P_{GM}$	$T_{VJ} = 125^\circ\text{C}$ $I_T = I_{TAVM}$	$t_p = 30 \mu\text{s}$ : 10 W $t_p = 300 \mu\text{s}$ : 5 W	
		0.5 W	
$V_{RGM}$		10 V	
$T_{VJ}$		-40...+150 °C	
$T_{VJM}$		150 °C	
$T_{stg}$		-40...+125 °C	
$V_{ISOL}$	50/60 Hz, RMS $I_{ISOL} \leq 1 \text{ mA}$	t = 1 min: 2500 V~ t = 1 s: 3000 V~	
		1.5...2.0/14...18 Nm/lb.in.	
<b>Weight</b>	typ.	18 g	

Data according to IEC 60747 and to a single thyristor/diode unless otherwise stated.

Symbol	Conditions	Characteristic Values	
$I_D, I_R$	$T_{VJ} = 125^\circ\text{C}; V_R = V_{RRM}; V_D = V_{DRM}$	$\leq$	5 mA
$V_T$	$I_T = 150 \text{ A}; T_{VJ} = 25^\circ\text{C}$	$\leq$	1.57 V
$V_{T0}$	For power-loss calculations only		0.85 V
$r_T$			5.6 m $\Omega$
$V_{GT}$	$V_D = 6 \text{ V}$	$T_{VJ} = 25^\circ\text{C}$ $T_{VJ} = -40^\circ\text{C}$	$\leq$ 1.5 V $\leq$ 1.9 V
$I_{GT}$	$V_D = 6 \text{ V}$	$T_{VJ} = 25^\circ\text{C}$ $T_{VJ} = -40^\circ\text{C}$	$\leq$ 100 mA $\leq$ 200 mA
$V_{GD}$	$T_{VJ} = 125^\circ\text{C}; V_D = \frac{2}{3} V_{DRM}$	$\leq$	0.2 V
$I_{GD}$		$\leq$	1 mA
$I_L$	$T_{VJ} = 25^\circ\text{C}; t_p = 10 \mu\text{s}$ $I_G = 0.45 \text{ A}; di_G/dt = 0.45 \text{ A}/\mu\text{s}$	$\leq$	200 mA
$I_H$	$T_{VJ} = 25^\circ\text{C}; V_D = 6 \text{ V}; R_{GK} = \infty$	$\leq$	100 mA
$t_{gd}$	$T_{VJ} = 25^\circ\text{C}; V_D = \frac{1}{2} V_{DRM}$ $I_G = 0.45 \text{ A}; di_G/dt = 0.45 \text{ A}/\mu\text{s}$	$\leq$	2 $\mu\text{s}$
$R_{thJC}$	per thyristor; DC		0.8 K/W
	per module		0.4 K/W
$R_{thCH}$	per thyristor; sine 180° el	typ.	0.12 K/W
	per module	typ.	0.06 K/W
$d_s$	Creeping distance on surface		11.2 mm
$d_A$	Creepage distance in air		17.0 mm
$a$	Max. allowable acceleration		50 m/s <sup>2</sup>

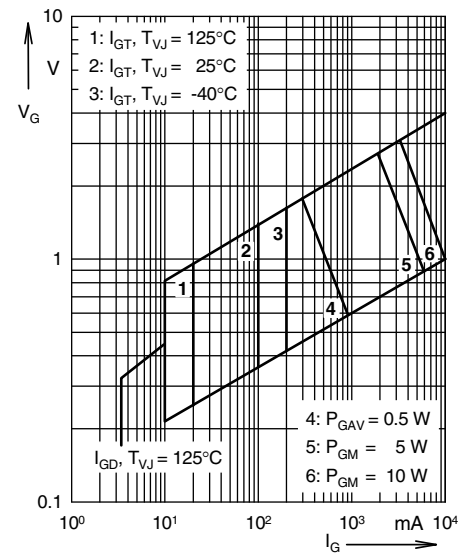
**Dimensions in mm (1 mm = 0.0394")**

Fig. 1 Gate trigger characteristics

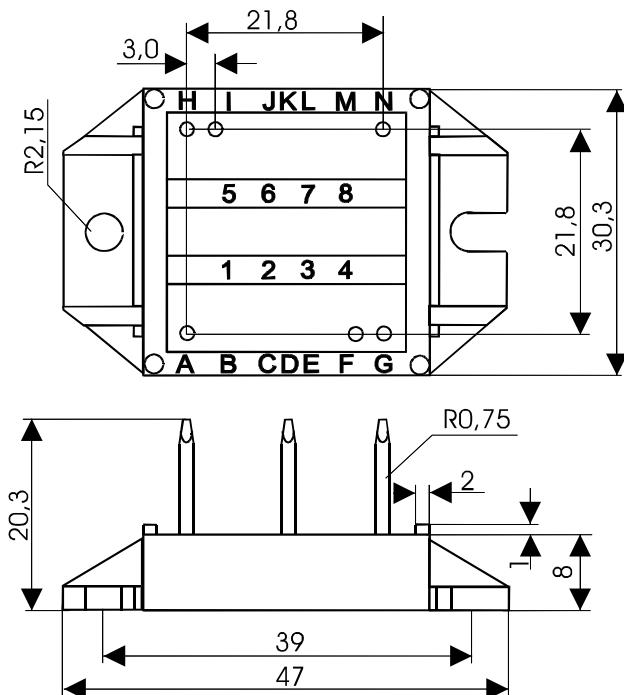
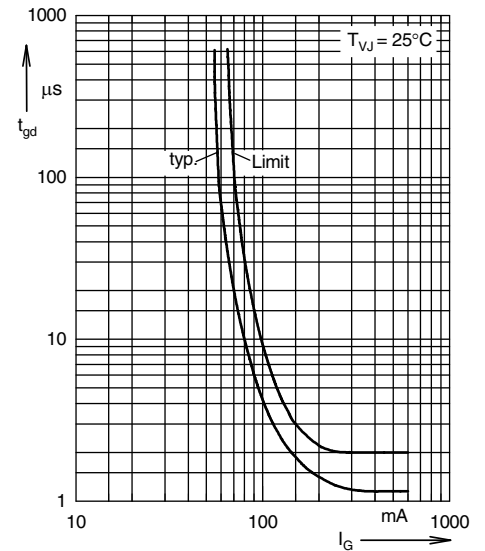

Fig. 2 Gate trigger delay time