

Converter - Brake - Inverter Module (CBI1)

NPT IGBT

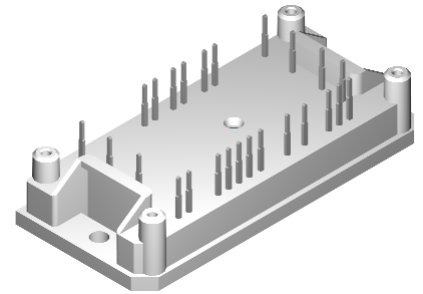
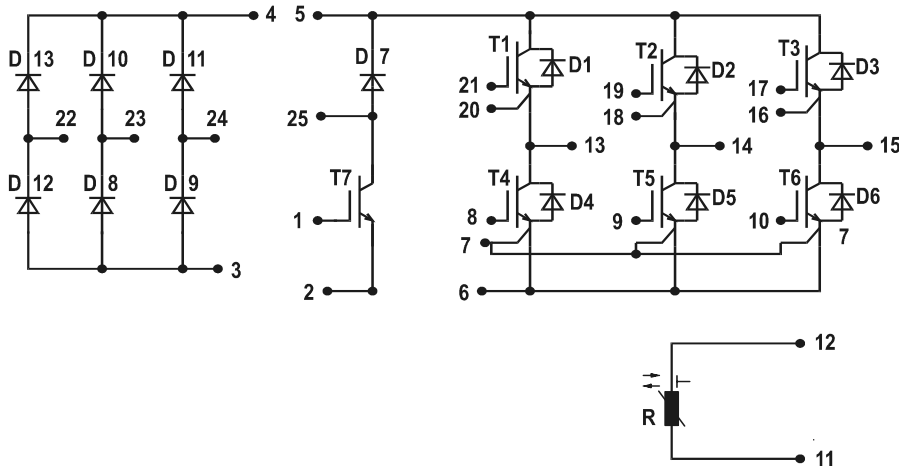

Three Phase Rectifier	Brake Chopper	Three Phase Inverter
$V_{RRM} = 1600V$	$V_{CES} = 600V$	$V_{CES} = 600V$
$I_{DAVM25} = 90A$	$I_{C25} = 12A$	$I_{C25} = 12A$
$I_{FSM} = 300A$	$V_{CE(sat)} = 2.5V$	$V_{CE(sat)} = 2.5V$

Input Rectifier Bridge D8 - D13

Symbol	Conditions	Maximum Ratings	
V_{RRM}		1600	V
I_{FAV}	$T_C = 80^\circ C$; sine 180°	22	A
I_{DAVM}	bridge output current; $T_C = 80^\circ C$; rect.; $d = 1/3$	61	A
I_{FSM}	$T_{VJ} = 25^\circ C$; $t = 10$ ms; sine 50 Hz	300	A
P_{tot}	$T_C = 25^\circ C$	50	W

Symbol	Conditions	Characteristic Values ($T_{VJ} = 25^\circ C$, unless otherwise specified)		
		min.	typ.	max.
V_F	$I_F = 30A$; $T_{VJ} = 25^\circ C$ $T_{VJ} = 125^\circ C$		1.1 1.2	1.45 V V
I_R	$V_R = V_{RRM}$; $T_{VJ} = 25^\circ C$ $T_{VJ} = 125^\circ C$		0.3	0.01 mA mA
R_{thJC} R_{thCH}	(per diode)		0.7	2.1 K/W K/W

Application: AC motor drives with

- Input from single or three phase grid
- Three phase synchronous or asynchronous motor
- electric braking operation

Features

- High level of integration - only one power semiconductor module required for the whole drive
- Inverter with NPT IGBTs
 - low saturation voltage
 - positive temperature coefficient
 - fast switching
 - short tail current
- Epitaxial free wheeling diodes with hiperfast and soft reverse recovery
- Industry standard package with insulated copper base plate and soldering pins for PCB mounting
- Temperature sense included

Output Inverter T1 - T6

Symbol	Conditions	Maximum Ratings	
V_{CES}	$T_{VJ} = 25^{\circ}\text{C}$ to 150°C	600	V
V_{GES}	Continuous	± 20	V
V_{GEM}	Transient	± 30	V
I_{C25}	$T_C = 25^{\circ}\text{C}$	12	A
I_{C80}	$T_C = 80^{\circ}\text{C}$	8	A
RBSOA	$V_{GE} = \pm 15\text{ V}$; $R_G = 47\ \Omega$; $T_{VJ} = 125^{\circ}\text{C}$ Clamped inductive load; $L = 100\ \mu\text{H}$	$I_{CM} = 24$ $V_{CEK} \leq V_{CES}$	A
t_{SC} (SCSOA)	$V_{CE} = 600\text{ V}$; $V_{GE} = \pm 15\text{ V}$; $R_G = 47\ \Omega$; $T_{VJ} = 125^{\circ}\text{C}$ non-repetitive	10	μs
P_{tot}	$T_C = 25^{\circ}\text{C}$	50	W

Symbol	Conditions	Characteristic Values ($T_{VJ} = 25^{\circ}\text{C}$, unless otherwise specified)			
		min.	typ.	max.	
$V_{CE(sat)}$	$I_C = 10\text{ A}$; $V_{GE} = 15\text{ V}$; $T_{VJ} = 25^{\circ}\text{C}$ $T_{VJ} = 125^{\circ}\text{C}$	2.5 2.9	3.1	V V	
$V_{GE(th)}$	$I_C = 0.2\text{ mA}$; $V_{GE} = V_{CE}$	3	5	V	
I_{CES}	$V_{CE} = V_{CES}$; $V_{GE} = 0\text{ V}$; $T_{VJ} = 25^{\circ}\text{C}$ $T_{VJ} = 125^{\circ}\text{C}$	0.5	0.1	mA mA	
I_{GES}	$V_{CE} = 0\text{ V}$; $V_{GE} = \pm 20\text{ V}$		100	nA	
$t_{d(on)}$ t_r $t_{d(off)}$ t_f E_{on} E_{off}	Inductive load, $T_{VJ} = 125^{\circ}\text{C}$ $V_{CE} = 400\text{ V}$; $I_C = 6\text{ A}$ $V_{GE} = \pm 15\text{ V}$; $R_G = 47\ \Omega$	20	20	ns	
		250	70	ns	
		0.3	0.2	mJ	
		0.3	0.2	mJ	
C_{ies}		$V_{CE} = 25\text{ V}$; $V_{GE} = 0\text{ V}$; $f = 1\text{ MHz}$	350		pF
Q_{Gon}		$V_{CE} = 480\text{ V}$; $V_{GE} = 15\text{ V}$; $I_C = 6\text{ A}$	32		nC
R_{thJC} R_{thCH}	(per IGBT)	0.95	2.8	K/W K/W	

Output Inverter D1 - D6

Symbol	Conditions	Maximum Ratings	
I_{F25}	$T_C = 25^{\circ}\text{C}$	21	A
I_{F80}	$T_C = 80^{\circ}\text{C}$	14	A

Symbol	Conditions	Characteristic Values		
		min.	typ.	max.
V_F	$I_F = 10\text{ A}$; $V_{GE} = 0\text{ V}$; $T_{VJ} = 25^{\circ}\text{C}$ $T_{VJ} = 125^{\circ}\text{C}$	1.5	2.3	V V
I_{RM} t_{rr}	$I_F = 12\text{ A}$; $di_F/dt = -100\text{ A}/\mu\text{s}$; $T_{VJ} = 125^{\circ}\text{C}$ $V_R = 100\text{ V}$; $V_{GE} = 0\text{ V}$	3.5		A
		80		ns
R_{thJC} R_{thCH}	(per diode)	0.85	2.5	K/W K/W

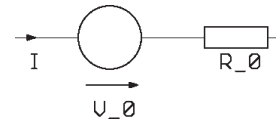
Equivalent Circuits for Simulation
Conduction

D8 - D13

Rectifier Diode (typ. at $T_J = 125^{\circ}\text{C}$)
 $V_0 = 0.90\text{ V}$; $R_0 = 12\text{ m}\Omega$

T1 - T6 / D1 - D6

IGBT (typ. at $V_{GE} = 15\text{ V}$; $T_J = 125^{\circ}\text{C}$)
 $V_0 = 1.4\text{ V}$; $R_0 = 150\text{ m}\Omega$

Free Wheeling Diode (typ. at $T_J = 125^{\circ}\text{C}$)
 $V_0 = 1.25\text{ V}$; $R_0 = 26\text{ m}\Omega$

T7 / D7

IGBT (typ. at $V_{GE} = 15\text{ V}$; $T_J = 125^{\circ}\text{C}$)
 $V_0 = 1.4\text{ V}$; $R_0 = 150\text{ m}\Omega$

Free Wheeling Diode (typ. at $T_J = 125^{\circ}\text{C}$)
 $V_0 = 1.25\text{ V}$; $R_0 = 26\text{ m}\Omega$

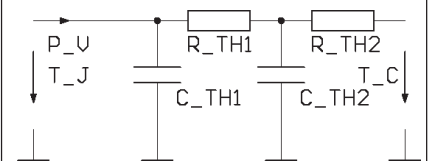
Thermal Response

D8 - D13

Rectifier Diode (typ.)
 $C_{th1} = tbd\text{ J/K}$; $R_{th1} = tbd\text{ K/W}$
 $C_{th2} = tbd\text{ J/K}$; $R_{th2} = tbd\text{ K/W}$

T1 - T6 / D1 - D6

IGBT (typ.)
 $C_{th1} = tbd\text{ J/K}$; $R_{th1} = tbd\text{ K/W}$
 $C_{th2} = tbd\text{ J/K}$; $R_{th2} = tbd\text{ K/W}$

Free Wheeling Diode (typ.)
 $C_{th1} = tbd\text{ J/K}$; $R_{th1} = tbd\text{ K/W}$
 $C_{th2} = tbd\text{ J/K}$; $R_{th2} = tbd\text{ K/W}$

T7 / D7

IGBT (typ.)
 $C_{th1} = tbd\text{ J/K}$; $R_{th1} = tbd\text{ K/W}$
 $C_{th2} = tbd\text{ J/K}$; $R_{th2} = tbd\text{ K/W}$

Free Wheeling Diode (typ.)
 $C_{th1} = tbd\text{ J/K}$; $R_{th1} = tbd\text{ K/W}$
 $C_{th2} = tbd\text{ J/K}$; $R_{th2} = tbd\text{ K/W}$

Brake Chopper T7

Symbol	Conditions	Maximum Ratings	
V_{CES}	$T_{VJ} = 25^{\circ}\text{C}$ to 150°C	600	V
V_{GES}	Continuous	± 20	V
V_{GEM}	Transient	± 30	V
I_{C25}	$T_C = 25^{\circ}\text{C}$	12	A
I_{C80}	$T_C = 80^{\circ}\text{C}$	8	A
RBSOA	$V_{GE} = \pm 15\text{ V}$; $R_G = 47\ \Omega$; $T_{VJ} = 125^{\circ}\text{C}$ Clamped inductive load; $L = 100\ \mu\text{H}$	$I_{CM} = 24$ $V_{CEK} \leq V_{CES}$	A
t_{SC} (SCSOA)	$V_{CE} = 600\text{ V}$; $V_{GE} = \pm 15\text{ V}$; $R_G = 47\ \Omega$; $T_{VJ} = 125^{\circ}\text{C}$ non-repetitive	10	μs
P_{tot}	$T_C = 25^{\circ}\text{C}$	50	W

Symbol	Conditions ($T_{VJ} = 25^{\circ}\text{C}$, unless otherwise specified)	Characteristic Values			
		min.	typ.	max.	
$V_{CE(sat)}$	$I_C = 10\text{ A}$; $V_{GE} = 15\text{ V}$; $T_{VJ} = 25^{\circ}\text{C}$ $T_{VJ} = 125^{\circ}\text{C}$		2.5 2.9	V V	
$V_{GE(th)}$	$I_C = 0.2\text{ mA}$; $V_{GE} = V_{CE}$	3		5 V	
I_{CES}	$V_{CE} = V_{CES}$; $V_{GE} = 0\text{ V}$; $T_{VJ} = 25^{\circ}\text{C}$ $T_{VJ} = 125^{\circ}\text{C}$		0.5	0.1 mA mA	
I_{GES}	$V_{CE} = 0\text{ V}$; $V_{GE} = \pm 20\text{ V}$			100 nA	
$t_{d(on)}$ t_r $t_{d(off)}$ t_f E_{on} E_{off}	Inductive load, $T_{VJ} = 125^{\circ}\text{C}$ $V_{CE} = 400\text{ V}$; $I_C = 6\text{ A}$ $V_{GE} = \pm 15\text{ V}$; $R_G = 47\ \Omega$		20 20 250 70	ns ns ns ns	
			0.3 0.2	mJ mJ	
C_{ies}		$V_{CE} = 25\text{ V}$; $V_{GE} = 0\text{ V}$; $f = 1\text{ MHz}$		350	pF
Q_{Gon}		$V_{CE} = 480\text{ V}$; $V_{GE} = 15\text{ V}$; $I_C = 6\text{ A}$		32	nC
R_{thJC} R_{thCH}			0.95		2.8 K/W K/W

Brake Chopper D7

Symbol	Conditions	Maximum Ratings	
V_{RRM}	$T_{VJ} = 25^{\circ}\text{C}$ to 150°C	600	V
I_{F25}	$T_C = 25^{\circ}\text{C}$	21	A
I_{F80}	$T_C = 80^{\circ}\text{C}$	14	A

Symbol	Conditions	Characteristic Values		
		min.	typ.	max.
V_F	$I_F = 10\text{ A}$; $T_{VJ} = 25^{\circ}\text{C}$ $T_{VJ} = 125^{\circ}\text{C}$		1.5	2.3 V V
I_R	$V_R = V_{RRM}$; $T_{VJ} = 25^{\circ}\text{C}$ $T_{VJ} = 125^{\circ}\text{C}$		0.2	0.06 mA mA
I_{RM} t_{tr}	$I_F = 12\text{ A}$; $di_F/dt = -100\text{ A}/\mu\text{s}$; $T_{VJ} = 125^{\circ}\text{C}$ $V_R = 100\text{ V}$		3.5 80	A ns
R_{thJC} R_{thCH}			0.85	

Temperature Sensor NTC

Symbol	Conditions	Characteristic Values		
		min.	typ.	max.
R_{25}	$T = 25^{\circ}\text{C}$	4.45	4.7	5.0 k Ω
$B_{25/85}$			3510	K

Module

Symbol	Conditions	Maximum Ratings		
		min.	typ.	max.
T_{VJ}	Operating	-40...+125		$^{\circ}\text{C}$
T_{JM}			150	$^{\circ}\text{C}$
T_{stg}		-40...+125		$^{\circ}\text{C}$
V_{ISOL}	$I_{ISOL} \leq 1 \text{ mA}$; 50/60 Hz		2500	V~
M_d	Mounting torque (M4)		2.0 - 2.2	Nm

Symbol	Conditions	Characteristic Values		
		min.	typ.	max.
d_s	Creepage distance (towards heatsink)	12.7		mm
d_A	Strike distance in air (towards heatsink)	12.7		mm
Weight			40	g

