

# Three Phase Half Controlled Rectifier Bridge with IGBT and Fast Recovery Diode for Braking System

$V_{RRM} = 1200/1600 \text{ V}$   
 $I_{dAV} = 120 \text{ A}$

## Preliminary data

$V_{RRM}$ V	Type
1200	VVZB 120-12 io2
1600	VVZB 120-16 io2

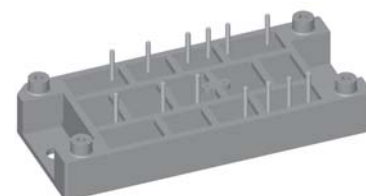
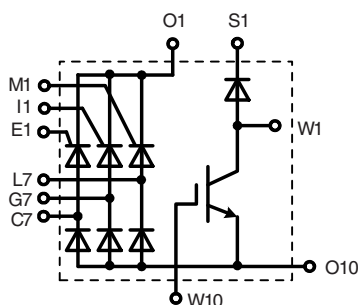

Symbol	Conditions	Maximum Ratings		
$I_{dAV}$	$T_{case} = 80^\circ\text{C}$ , sinusoidal 120°	120	A	
$I_{FRMS}/I_{TRMS}$	$T_{case} = 80^\circ\text{C}$ , per leg	77	A	
$I_{FSM}/I_{TSM}$	$T_{VJ} = 25^\circ\text{C}$ , $t = 10 \text{ ms}$ , $V_R = 0 \text{ V}$	750	A	
	$T_{VJ} = 150^\circ\text{C}$ , $t = 10 \text{ ms}$ , $V_R = 0 \text{ V}$	670	A	
$I^2t$	$T_{VJ} = 25^\circ\text{C}$ , $t = 10 \text{ ms}$ , $V_R = 0 \text{ V}$	2810	A	
	$T_{VJ} = 150^\circ\text{C}$ , $t = 10 \text{ ms}$ , $V_R = 0 \text{ V}$	2240	A	
$(di/dt)_{cr}$	$T_{VJ} = T_{VJM}$ , $f = 50 \text{ Hz}$ , $t_p = 200 \mu\text{s}$ repetitive, $I_T = 150 \text{ A}$	150	A/ $\mu\text{s}$	
	$V_D = \frac{2}{3} V_{DRM}$ $I_G = 0.45 \text{ A}$ , $di_G/dt = 0.45 \text{ A}/\mu\text{s}$ non repetitive, $I_T = I_{d(AV)}/3$	500	A/ $\mu\text{s}$	
$(dv/dt)_{cr}$	$T_{VJ} = T_{VJM}$ ; $V_{DR} = \frac{2}{3} V_{DRM}$ $R_{GK} = \infty$ ; method 1 (linear voltage rise)	1000	V/ $\mu\text{s}$	
$P_{GM}$	$T_{VJ} = T_{VJM}$ , $t_p = 30 \mu\text{s}$	10	W	
	$I_T = I_{d(AV)}/3$ , $t_p = 300 \mu\text{s}$	5	W	
	$t_p = 10 \text{ ms}$	1	W	
$P_{GAVM}$		0.5	W	
$V_{CES}$ $V_{GE}$	$T_{VJ} = 25^\circ\text{C}$ to $150^\circ\text{C}$	1200	V	
	Continuous	$\pm 20$	V	
$I_{C25}$ $I_{C80}$ $I_{CM}$ $P_{tot}$	IGBT	$T_{case} = 25^\circ\text{C}$ , DC	140	A
		$T_{case} = 80^\circ\text{C}$ , DC	100	A
		$t_p = \text{Pulse width limited by } T_{VJM}$	280	A
		$T_{case} = 80^\circ\text{C}$	570	W
$V_{RRM}$ $I_{F(AV)}$ $I_{F(RMS)}$ $I_{FRM}$ $I_{FSM}$ $P_{tot}$	Fast Recovery Diode		1200	V
		$T_{case} = 80^\circ\text{C}$ , rectangular $d = 0.5$	27	A
		$T_{case} = 80^\circ\text{C}$ , rectangular $d = 0.5$	38	A
		$T_{case} = 80^\circ\text{C}$ , $t_p = 10 \mu\text{s}$ , $f = 5 \text{ kHz}$	tbd	A
		$T_{VJ} = 45^\circ\text{C}$ , $t = 10 \text{ ms}$	200	A
		$T_{VJ} = 150^\circ\text{C}$ , $t = 10 \text{ ms}$	180	A
$T_{case} = 80^\circ\text{C}$	64	W		

## Features

- Soldering connections for PCB mounting
- Isolation voltage 3600 V~
- Ultrafast freewheel diode
- Convenient package outline

## Applications

- Drive Inverters with brake system

## Advantages

- 2 functions in one package
- No external isolation
- Easy to mount with two screws
- Suitable for wave soldering
- High temperature and power cycling capability

Data according to IEC 60747

IXYS reserves the right to change limits, test conditions and dimensions.

Symbol	Conditions	Characteristic Values ( $T_{VJ} = 25^{\circ}\text{C}$ , unless otherwise specified)		
		min.	typ.	max.
$I_R, I_D$	$V_R = V_{RRM}/V_{DRM}$ $V_R = V_{RRM}/V_{DRM}; T_{VJ} = 150^{\circ}\text{C}$		0.3	mA 5 mA
$V_F, V_T$	$I_F = 100\text{ A}$			1.47 V
$V_{T0}$	For power-loss calculations only			0.85 V
$r_T$	$T_{VJ} = 150^{\circ}\text{C}$			5 m $\Omega$
$V_{GT}$	$V_D = 6\text{ V}; T_{VJ} = 25^{\circ}\text{C}$ $T_{VJ} = -40^{\circ}\text{C}$			1.5 V 1.6 V
$I_{GT}$	$V_D = 6\text{ V}; T_{VJ} = 25^{\circ}\text{C}$ $T_{VJ} = -40^{\circ}\text{C}$			100 mA 200 mA
$V_{GD}$	$T_{VJ} = T_{VJM}; V_D = \frac{2}{3} V_{DRM}$ $T_{VJ} = T_{VJM}; V_D = \frac{2}{3} V_{DRM}$			0.2 V
$I_{GD}$				10 mA
$I_L$	$V_D = 6\text{ V}; t_G = 30\ \mu\text{s}$ $di_G/dt = 0.45\text{ A}/\mu\text{s}; I_G = 0.45\text{ A}$			450 mA
$I_H$	$T_{VJ} = T_{VJM}; V_D = 6\text{ V}; R_{GK} = \infty$			200 mA
$t_{gd}$	$V_D = \frac{1}{2} V_{DRM}$ $di_G/dt = 0.45\text{ A}/\mu\text{s}; I_G = 0.45\text{ A}$			2 $\mu\text{s}$
$t_q$	$T_{VJ} = T_{VJM}; V_R = 100\text{ V}; V_D = \frac{2}{3} V_{DRM}; t_p = 200\ \mu\text{s}$ $dv/dt = 10\text{ V}/\mu\text{s}; I_T = 120\text{ A}; -di/dt = 10\text{ A}/\mu\text{s}$			150 $\mu\text{s}$
$Q_S$	$T_{VJ} = T_{VJM}$ $-di/dt = 0.64\text{ A}/\mu\text{s}; I_T/I_F = 50\text{ A}$			90 $\mu\text{C}$
$I_{RM}$				11 A
$R_{thJC}$	per thyristor/diode; sine $120^{\circ}$ el.			1 K/W
$R_{thJH}$	per thyristor/diode; sine $120^{\circ}$ el.			1.3 K/W
$V_{BR(CES)}$	$V_{GS} = 0\text{ V}; I_C = 1\text{ mA}$	1200		V
$V_{GE(th)}$	$I_C = 4\text{ mA}$	4.5		6.5 V
$I_{GES}$	$V_{GE} = \pm 20\text{ V}$			500 nA
$I_{CES}$	$V_{CE} = V_{CES}$ $V_{CE} = V_{CES}; T_{VJ} = 125^{\circ}\text{C}$			0.2 mA 1 mA
$V_{CESat}$	$V_{GE} = 15\text{ V}; I_C = 50\text{ A}$			2.1 V
$t_{sc}$ (SCSOA)	$V_{GE} = 15\text{ V}; V_{CE} = 900\text{ V}; T_{VJ} = 125^{\circ}\text{C}$ $R_G = 15\ \Omega$ ; non repetitive			10 $\mu\text{s}$
RBSOA	$V_{GE} = 15\text{ V}; V_{CE} = 1200\text{ V}; T_{VJ} = 125^{\circ}\text{C}$ $R_G = 15\ \Omega$ ; Clamped Inductive load; $L = 100\ \mu\text{H}$			150 A
$C_{ies}$	$V_{CE} = 25\text{ V}; f = 1\text{ MHz}; V_{GE} = 0\text{ V}$		5.7	nF
$t_{d(on)}$	$V_{CE} = 600\text{ V}; I_C = 50\text{ A}$ $V_{GE} = 15\text{ V}; R_G = 15\ \Omega$ Inductive load; $L = 100\ \mu\text{H}$ $T_{VJ} = 125^{\circ}\text{C}$		170	ns
$t_{d(off)}$			680	ns
$E_{on}$			11	mJ
$E_{off}$			8	mJ
$R_{thJC}$				0.22 K/W
$R_{thCH}$			0.1	K/W

Symbol	Conditions	Characteristic Values		
		(T <sub>VJ</sub> = 25°C, unless otherwise specified)		
		min.	typ.	max.
I <sub>R</sub>	V <sub>R</sub> = V <sub>RRM</sub> ; T <sub>VJ</sub> = 25°C			0.75 mA
	V <sub>R</sub> = 0.8 V <sub>RRM</sub> ; T <sub>VJ</sub> = 150°C		3	7 mA
V <sub>F</sub>	I <sub>F</sub> = 30 A; T <sub>VJ</sub> = 25°C			2.55 V
V <sub>T0</sub>	For power-loss calculations only			1.65 V
r <sub>T</sub>	T <sub>VJ</sub> = 150°C			18.2 mΩ
I <sub>RM</sub>	I <sub>F</sub> = 30 A; -di <sub>F</sub> /dt = 240 A/μs V <sub>R</sub> = 100 V		16	18 A
t <sub>rr</sub>	I <sub>F</sub> = 1 A; -di <sub>F</sub> /dt = 100 A/μs V <sub>R</sub> = 30 V		40	60 ns
R <sub>thJC</sub>				1.1 K/W
R <sub>thJH</sub>				1.5 K/W
		<b>Fast Recovery Diode</b>		
		<b>Common Specification</b>		
		<b>Maximum Ratings</b>		
T <sub>VJ</sub>				-40...+150 °C
T <sub>VJM</sub>				150 °C
T <sub>stg</sub>				-40...+125 °C
V <sub>ISOL</sub>	50/60 Hz	t = 1 min		3000 V~
	I <sub>ISOL</sub> ≤ 1 mA	t = 1 s		3600 V~
M <sub>d</sub>	Mounting torque (M5) (10-32 UNF)			2-2.5 Nm
				18-22 lb.in.
Weight	typ.			80 g
d <sub>s</sub>	Creep distance on surface			12.7 mm
d <sub>A</sub>	Strike distance in air			11 mm
a	Maximum allowable acceleration			50 m/s <sup>2</sup>

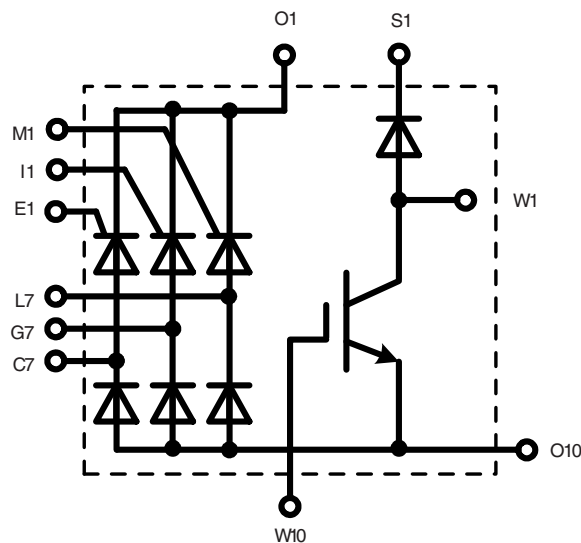

Dimensions in mm (1 mm = 0.0394")

Detail X M 2:1

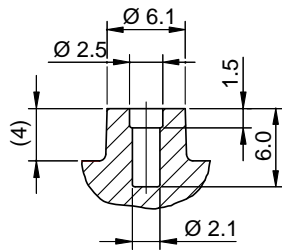

Detail Y M 5:1

