

Three Phase AC Controller Modules

$$I_{RMS} = 3 \times 143 \text{ A}$$

$$V_{RRM} = 1200-1600 \text{ V}$$

Preliminary data

V_{RSM} V_{DSM} V	V_{RRM} V_{DRM} V	Type
1200	1200	VWO 140-12io1
1400	1400	VWO 140-14io1
1600	1600	VWO 140-16io1

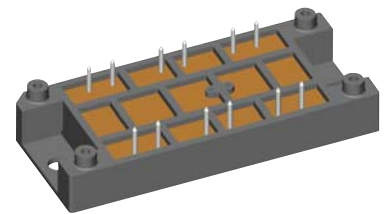
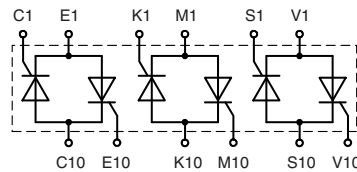

pin configuration see outlines

Symbol	Conditions	Maximum Ratings	
I_{RMS}	$T_C = 85^\circ\text{C}$; 50 - 400 Hz (per phase)	101 A	
I_{RMS}	$T_C = 85^\circ\text{C}$; 50 - 400 Hz (per phase) for 10 sec.	143 A	
I_{TAVM}	$T_C = 85^\circ\text{C}$; (180° sine)	46 A	
I_{TSM}	$T_{VJ} = 45^\circ\text{C}$ $V_R = 0$	t = 10 ms (50 Hz), sine t = 8.3 ms (60 Hz), sine	1150 A 1240 A
	$T_{VJ} = 125^\circ\text{C}$ $V_R = 0$	t = 10 ms (50 Hz), sine t = 8.3 ms (60 Hz), sine	1040 A 1120 A
I^2t	$T_{VJ} = 45^\circ\text{C}$ $V_R = 0$	t = 10 ms (50 Hz), sine t = 8.3 ms (60 Hz), sine	6610 A ² s 6460 A ² s
	$T_{VJ} = 125^\circ\text{C}$ $V_R = 0$	t = 10 ms (50 Hz), sine t = 8.3 ms (60 Hz), sine	5410 A ² s 5270 A ² s
$(di/dt)_{cr}$	$T_{VJ} = 125^\circ\text{C}$ f = 50 Hz, $t_p = 200 \mu\text{s}$ $V_D = \frac{2}{3} V_{DRM}$ $I_G = 0.45 \text{ A}$ $di_G/dt = 0.45 \text{ A}/\mu\text{s}$	repetitive, $I_T = 45 \text{ A}$ non repetitive, $I_T = I_{TAVM}$	150 A/ μs 500 A/ μs
$(dv/dt)_{cr}$	$T_{VJ} = 125^\circ\text{C}$; $R_{GK} = \infty$; method 1 (linear voltage rise)	$V_{DR} = \frac{2}{3} V_{DRM}$	1000 V/ μs
P_{GM}	$T_{VJ} = 125^\circ\text{C}$ $I_T = I_{TAVM}$	$t_p = 30 \mu\text{s}$	10 W
		$t_p = 300 \mu\text{s}$	5 W
P_{GAVM}			0.5 W
V_{RGM}			10 V
T_{VJ}			-40...+125 °C
T_{VJM}	for 10 sec.		150 °C
T_{stg}			-40...+125 °C
V_{ISOL}	50/60 Hz, RMS $I_{ISOL} \leq 1 \text{ mA}$	t = 1 min	3000 V~
		t = 1 s	3600 V~
M_d	Mounting torque (M5)		2-2.5 Nm.
			18-22 lb.in.
Weight	typ.		80 g

Data according to IEC 60747 refer to a single thyristor unless otherwise stated.

Features

- Thyristor controller for AC (circuit W3C acc. to IEC) for mains frequency
- Package with DCB base plate
- Isolation voltage 3600 V~
- Planar passivated chips
- UL applied

Applications

- Switching and control of three phase AC circuits
- Softstart AC motor controller
- Solid state switches
- Light and temperature control

Advantages

- Easy to mount with two screws
- Space and weight savings
- Improved temperature and power cycling
- High power density

Symbol	Conditions	Characteristic Values	
I_D, I_R	$T_{VJ} = 125^\circ\text{C}; V_R = V_{RRM}; V_D = V_{DRM}$	\leq	5 mA
V_T	$I_T = 140 \text{ A}; T_{VJ} = 25^\circ\text{C}$	\leq	1.5 V
V_{T0}	For power-loss calculations only		0.85 V
r_T			5.2 m Ω
V_{GT}	$V_D = 6 \text{ V}; T_{VJ} = 25^\circ\text{C}$	\leq	1.5 V
	$T_{VJ} = -40^\circ\text{C}$	\leq	1.6 V
I_{GT}	$V_D = 6 \text{ V}; T_{VJ} = 25^\circ\text{C}$	\leq	100 mA
	$T_{VJ} = -40^\circ\text{C}$	\leq	200 mA
V_{GD}	$T_{VJ}=125^\circ\text{C}; V_D = \frac{2}{3} V_{DRM}$	\leq	0.2 V
I_{GD}		\leq	5 mA
I_L	$T_{VJ} = 25^\circ\text{C}; t_p = 10 \mu\text{s}$ $I_G = 0.45 \text{ A}; di_G/dt = 0.45 \text{ A}/\mu\text{s}$	\leq	450 mA
I_H	$T_{VJ} = 25^\circ\text{C}; V_D = 6 \text{ V}; R_{GK} = \infty$	\leq	200 mA
t_{gd}	$T_{VJ} = 25^\circ\text{C}; V_D = \frac{1}{2} V_{DRM}$ $I_G = 0.45 \text{ A}; di_G/dt = 0.45 \text{ A}/\mu\text{s}$	\leq	2 μs
t_q	$T_{VJ}=125^\circ\text{C}; I_T = 20 \text{ A}, t_p = 200 \mu\text{s}; di/dt = -10 \text{ A}/\mu\text{s}$ typ. $V_R = 100 \text{ V}; dv/dt = 15 \text{ V}/\mu\text{s}; V_D = \frac{2}{3} V_{DRM}$		150 μs
R_{thJC}	per thyristor; sine 180°el		0.6 K/W
	per module		0.1 K/W
R_{thJK}	per thyristor; sine 180°el		0.7 K/W
	per module		0.117 K/W
d_s	Creeping distance on surface		12.7 mm
d_A	Creepage distance in air		9.4 mm
a	Max. allowable acceleration		50 m/s ²

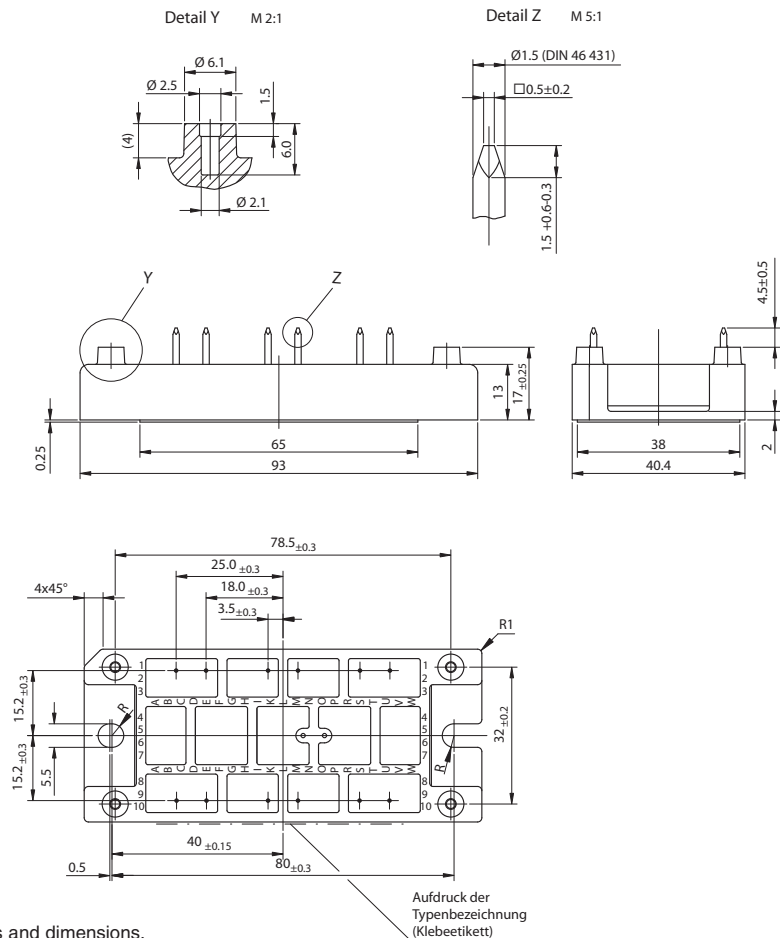
Dimensions in mm (1 mm = 0.0394")

IXYS reserves the right to change limits, test conditions and dimensions.

20080828a