

# Three Phase AC Controller Modules

$$I_{RMS} = 3 \times 83 \text{ A}$$

$$V_{RRM} = 1200-1600 \text{ V}$$

Preliminary data

$V_{RSM}$ $V_{DSM}$ V	$V_{RRM}$ $V_{DRM}$ V	Type
1200	1200	VWO 85-12io1
1400	1400	VWO 85-14io1
1600	1600	VWO 85-16io1

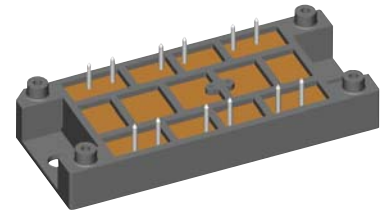
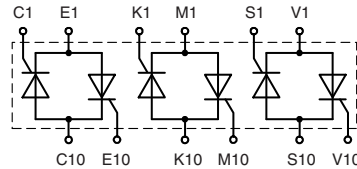

pin configuration see outlines

Symbol	Conditions	Max. Ratings per phase	
$I_{RMS}$	$T_C = 85^\circ\text{C}$ ; 50 - 400 Hz (per phase)	59	A
$I_{RMS}$	$T_C = 85^\circ\text{C}$ ; 50 - 400 Hz (per phase) for 10 sec.	83	A
$I_{TAVM}$	$T_C = 85^\circ\text{C}$ ; (180° sine)	27	A
$I_{TSM}$	$T_{VJ} = 45^\circ\text{C}$ $V_R = 0$	t = 10 ms (50 Hz), sine	520 A
		t = 8.3 ms (60 Hz), sine	560 A
$I^2t$	$T_{VJ} = 45^\circ\text{C}$ $V_R = 0$	t = 10 ms (50 Hz), sine	1350 A <sup>2</sup> s
		t = 8.3 ms (60 Hz), sine	1320 A <sup>2</sup> s
$(di/dt)_{cr}$	$T_{VJ} = 125^\circ\text{C}$ f = 50 Hz, $t_p = 200 \mu\text{s}$ $V_D = \frac{2}{3} V_{DRM}$ $I_G = 0.45 \text{ A}$ $di_G/dt = 0.45 \text{ A}/\mu\text{s}$	repetitive, $I_T = 45 \text{ A}$	150 A/ $\mu\text{s}$
		non repetitive, $I_T = I_{TAVM}$	500 A/ $\mu\text{s}$
$(dv/dt)_{cr}$	$T_{VJ} = 125^\circ\text{C}$ $R_{GK} = \infty$ ; method 1 (linear voltage rise)	$V_{DR} = \frac{2}{3} V_{DRM}$	1000 V/ $\mu\text{s}$
$P_{GM}$	$T_{VJ} = 125^\circ\text{C}$ $I_T = I_{TAVM}$	$t_p = 30 \mu\text{s}$	10 W
		$t_p = 300 \mu\text{s}$	5 W
$P_{GAVM}$			0.5 W
$V_{RGM}$			10 V
$T_{VJ}$			-40...+125 °C
$T_{VJM}$	for 10 sec.		150 °C
$T_{stg}$			-40...+125 °C
$V_{ISOL}$	50/60 Hz, RMS	t = 1 min	3000 V~
	$I_{ISOL} \leq 1 \text{ mA}$	t = 1 s	3600 V~
$M_d$	Mounting torque (M5)		2-2.5 Nm.
			18-22 lb.in.
Weight	typ.		80 g

Data according to IEC 60747 refer to a single thyristor unless otherwise stated.

## Features

- Thyristor controller for AC (circuit W3C acc. to IEC) for mains frequency
- Package with DCB base plate
- Isolation voltage 3600 V~
- Planar passivated chips
- UL applied

## Applications

- Switching and control of three phase AC circuits
- Softstart AC motor controller
- Solid state switches
- Light and temperature control

## Advantages

- Easy to mount with two screws
- Space and weight savings
- Improved temperature and power cycling
- High power density

Symbol	Conditions	Characteristic Values
$I_D, I_R$	$T_{VJ} = 125^\circ\text{C}; V_R = V_{RRM}; V_D = V_{DRM}$	$\leq 5$ mA
$V_T$	$I_T = 85$ A; $T_{VJ} = 25^\circ\text{C}$	$\leq 1.67$ V
$V_{T0}$	For power-loss calculations only	0.85 V
$r_T$		11 m $\Omega$
$V_{GT}$	$V_D = 6$ V $T_{VJ} = 25^\circ\text{C}$	$\leq 1.5$ V
	$T_{VJ} = -40^\circ\text{C}$	$\leq 1.6$ V
$I_{GT}$	$V_D = 6$ V $T_{VJ} = 25^\circ\text{C}$	$\leq 100$ mA
	$T_{VJ} = -40^\circ\text{C}$	$\leq 200$ mA
$V_{GD}$	$T_{VJ} = 125^\circ\text{C}$ $V_D = \frac{2}{3} V_{DRM}$	$\leq 0.2$ V
$I_{GD}$		$\leq 5$ mA
$I_L$	$T_{VJ} = 25^\circ\text{C}; t_p = 10$ $\mu\text{s}$ $I_G = 0.45$ A; $di_G/dt = 0.45$ A/ $\mu\text{s}$	$\leq 450$ mA
$I_H$	$T_{VJ} = 25^\circ\text{C}; V_D = 6$ V; $R_{GK} = \infty$	$\leq 200$ mA
$t_{gd}$	$T_{VJ} = 25^\circ\text{C}; V_D = \frac{1}{2} V_{DRM}$ $I_G = 0.45$ A; $di_G/dt = 0.45$ A/ $\mu\text{s}$	$\leq 2$ $\mu\text{s}$
$t_q$	$T_{VJ} = 125^\circ\text{C}; I_T = 20$ A, $t_p = 200$ $\mu\text{s}$ ; $di/dt = -10$ A/ $\mu\text{s}$ $V_R = 100$ V; $dv/dt = 15$ V/ $\mu\text{s}$ ; $V_D = \frac{2}{3} V_{DRM}$	typ. 150 $\mu\text{s}$
$R_{thJC}$	per thyristor	0.92 K/W
	per module	0.154 K/W
$R_{thJK}$	per thyristor	1.22 K/W
	per module	0.204 K/W
$d_s$	Creeping distance on surface	12.7 mm
$d_A$	Creepage distance in air	9.4 mm
$a$	Max. allowable acceleration	50 m/s <sup>2</sup>

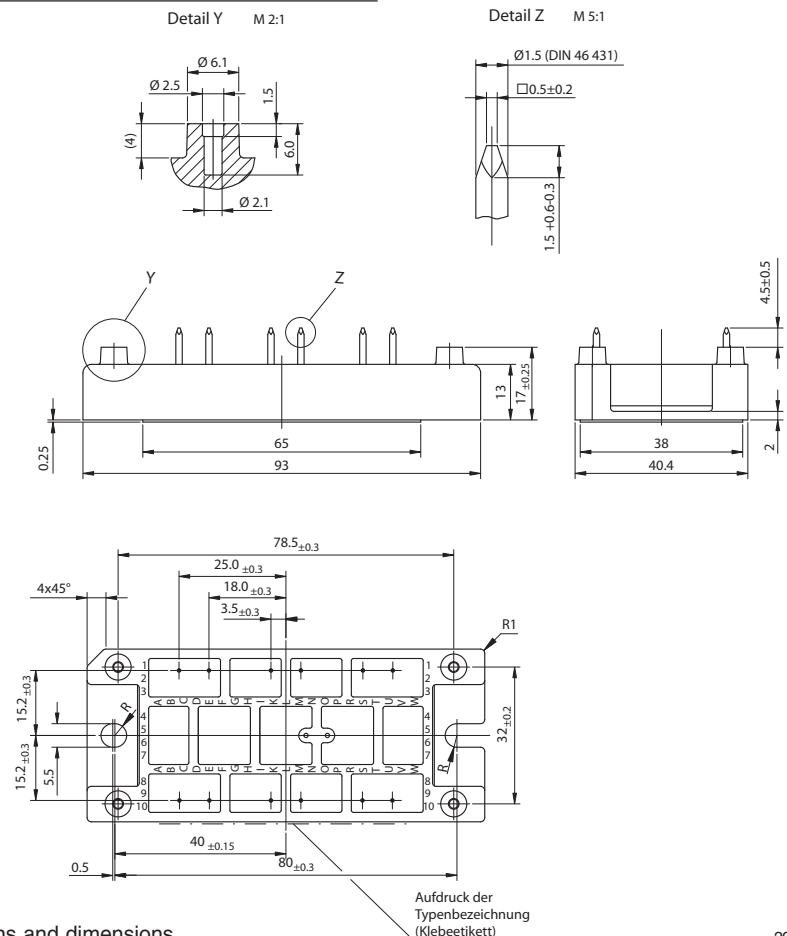
**Dimensions in mm (1 mm = 0.0394")**

IXYS reserves the right to change limits, test conditions and dimensions.

20080828a